

1 2 3 4 5 6

A

B

C

D

A

B

C

D

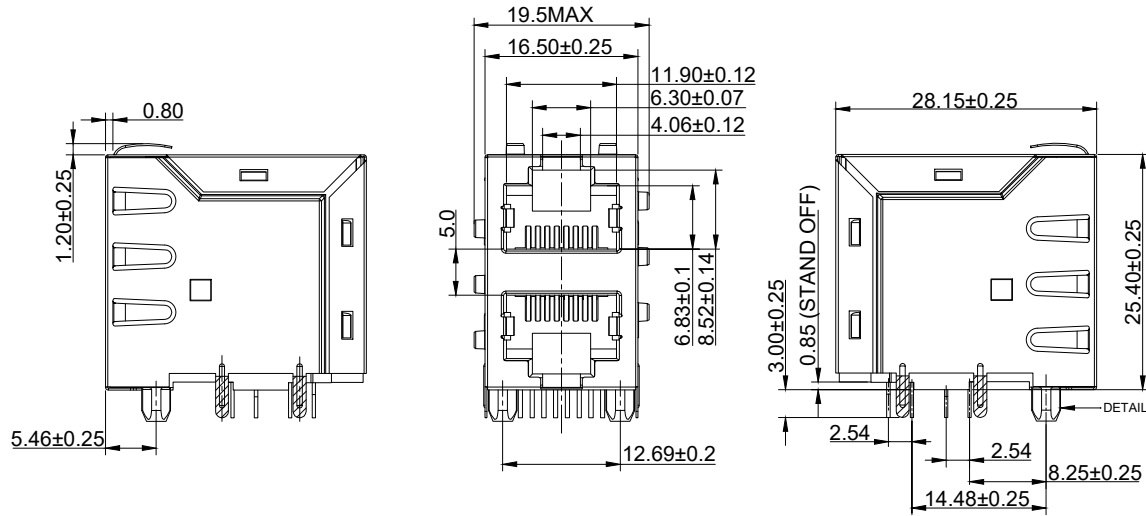

NOTES:

- MECHANICAL
HOUSING&INSERT : LCP UL94V-0
CONTACT : PHOSPHOR BRONZE
PLATING : CONTACT AREA SELECTIVE
GOLD PLATING SOLDER
AREA TIN PLATING NICKEL
PLATING OVERALL
- SHIELD : BRASS
DURABILITY : 750 CYCLES MIN.
MATING/UNMATING FORCE : 30N MAX.
RETENTION STRENGTH : 50N FOR 60S±5S

ELECTRICAL

- VOLTAGE RATING : 150VAC RMS
CURRENT RATING : 1.5 AMPS
CONTACT RESISTANCE : 20 mΩ MAX.
INSULATION RESISTANCE : 1000 MΩ MIN. @500V DC
DIELECTRIC STRENGTH : 1000V DC OR AC PEAK
ONE CONTACT TO ALL
OTHER CONTACTS
CONNECTED TOGETHER
1500V DC OR AC PEAK
ALL CONTACTS
CONNECTED TOGETHER
TO SHIELD

ENVIRONMENTAL

- STORAGE : -40°C ~ +85°C
OPERATION : -40°C ~ +85°C

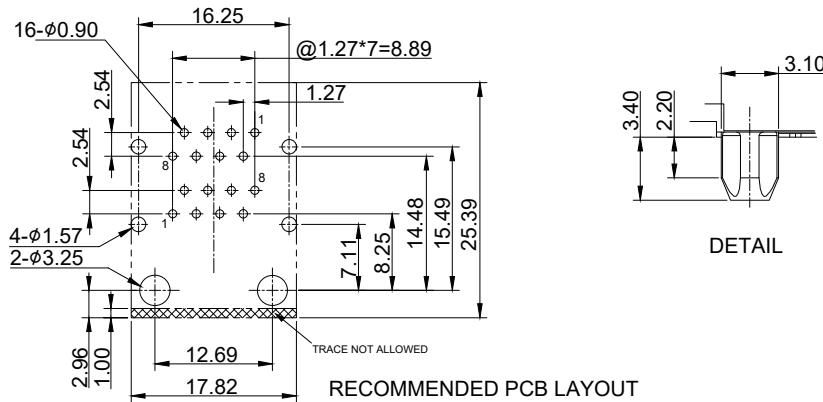

DETAIL

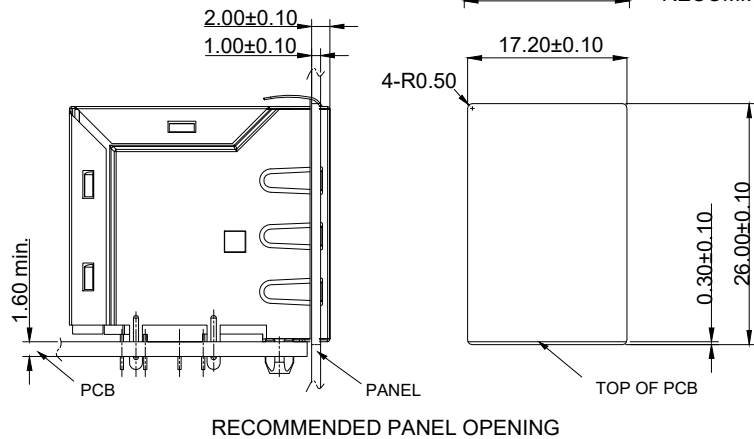

 E.S. GLOBAL TOP		UNIT	mm
		REVISION	02
PRODUCT		RJ45 2X1 SIDE ENTRY JACK	
DWG NO.		PART NO.	
EZC1445-218S11-01			
PROJECTION	SCALE	SHEET	1 OF 1
		TOLERANCES	
		00~15 ± 0.15	
		15~30 ± 0.20	
		30~ ± 0.25	
		ANGLES ± 1°	

1 2 3 4 5 6