

**NOTES:**

MECHANICAL

- HOUSING & INSERT : LCP UL94V-0, BLACK
- CONTACT : PHOSPHOR BRONZE
- CONTACT PLATING : CONTACT AREA SELECTIVE GOLD  
PLATING SOLDER AREA TIN  
OVER NICKEL
- SHIELD : BRASS PLATED NICKEL
- MATING/UNMATING FORCE : 30N Max.
- RETENTION STRENGTH : 50N FOR 60s±5s.
- DURABILITY : 750 CYCLES MIN.

ELECTRICAL

- VOLTAGE RATING : 150V AC RMS.
- CURRENT RATING : 1.5 AMP
- CONTACT RESISTANCE : 20mΩ Max.
- INSULATION RESISTANCE : 1000MΩ Min. @500V DC
- DIELECTRIC STRENGTH : CONTACT TO CONTACT 1000V  
DC OR AC PEAK, CONTACT TO  
SCREEN AND TEST PANEL  
1500V DC OR AC PEAK @0.5mA  
50Hz OR 60Hz ONE MINUTE



ENVIRONMENTAL

- STORAGE TEMPERATURE : -40°C~+85°C
- OPERATION TEMPERATURE : -40°C~+85°C

		UNIT	mm
		REVISION	02
PRODUCT		RJ45 2x6 SIDE ENTRY JACK WITH LED	
DWG NO.		PART NO.	
EZC1445-268S11-01			
PROJECTION	SCALE	SHEET	1 OF 2

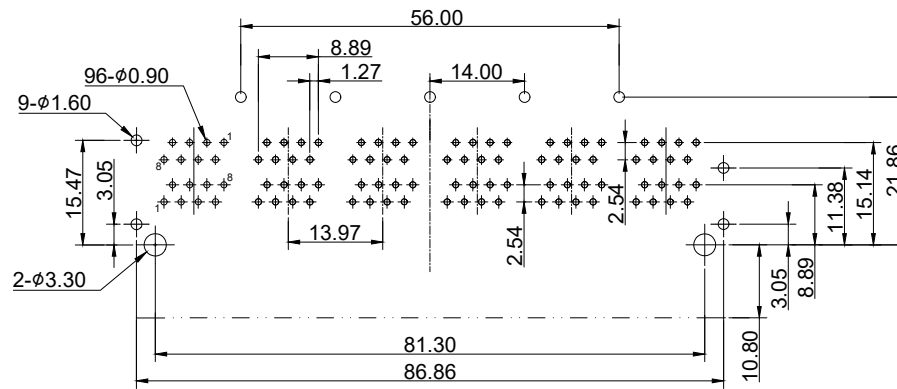
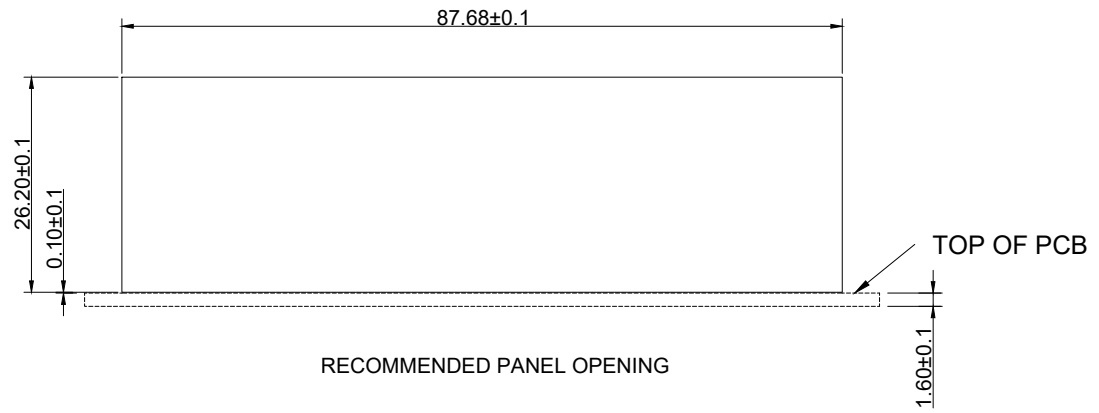
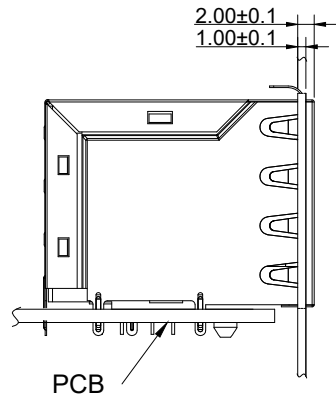
TOLERANCES  
 00~15 ± 0.15  
 15~30 ± 0.20  
 30~ ± 0.25  
 ANGLES ± 1°



 <b>E.S. GLOBAL TOP</b>		UNIT	mm
		REVISION	02
PRODUCT		RJ45 2×6 SIDE ENTRY JACK WITH LED	
DWG NO.		PART NO.	
EZC1445-268S11-01			
PROJECTION	SCALE	SHEET	2 OF 2
			

TOLERANCES

00~15 ± 0.15  
15~30 ± 0.20  
30~ ± 0.25  
ANGLES ± 1°