

RECOMMENDED PCB LAYOUT

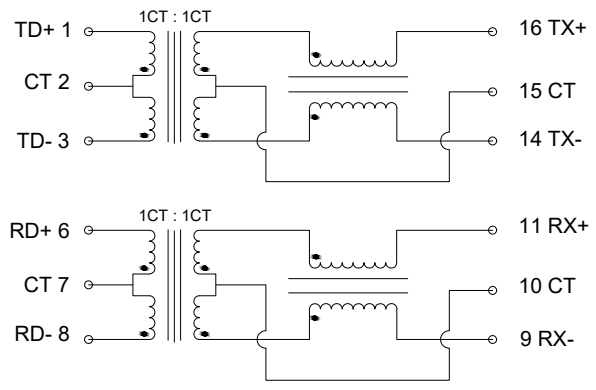

CIRCUIT SCHEMATIC

PARAMETER	SPECIFICATIONS	
	TURNS RATIO	(1-3) : (16-14)
(6-8) : (11-9)		1:1 ±3%
INDUCTANCE	(1-3) : (16-14)	365uH MIN. @ 0.1V 100KHz 8mA DC BIAS
	(6-8) : (11-9)	0.35uH MAX @1MHz
LEAKAGE INDUCTANCE	1-3 BY 16&14 SHORT	0.35uH MAX @1MHz
	6-8 BY 11&19 SHORT	0.35uH MAX @1MHz
INTERWINDING CAPACITANCE	(1-3) : (16-14)	27pF MAX @1MHz
	(6-8) : (11-9)	27pF MAX @1MHz
DC RESISTANCE	(16-14) : (11-9)	1.1Ω MAX.
RETURN LOSS	1-30MHz	-18dB Min.
	30-80MHz	-12dB Min.
DIELECTRIC WITHSTAND	(1-3) : (16-14)	1600V AC
	(6-8) : (11-9)	1600V AC
INSERTION LOSS	100KMz-100MHz	-1.0dB Max.
CROSS TALK	1-100MHz	35dB Min.
COMMON TO COMMON MODE ATTENUATION	30-100MHz	30dB Min.
OPERATING TEMPERATURE	0 ~ 70°C	
STORAGE TEMPERATURE	-40°C ~ 85°C	

		UNIT	mm
		REVISION	X
PRODUCT		LAN FILTER	
DWG NO.		PART NO.	
EZCB1601-01			
PROJECTION	SCALE	SHEET	1 OF 1

1 2 3 4 5 6

A

B

C

D

A

B

C

D

1 2 3 4 5 6