

RECOMMENDED PANEL OPENING

NOTES:
 MECHANICAL
 HOUSING & INSERT : PBT BLACK UL94 V-0
 CONTACT : COPPER ALLOY
 PLATING : NICKEL
 SHIELD : BRASS

ENVIRONMENTAL
 STORAGE : -40°C ~ +85°C
 OPERATION : 0°C ~ +70°C

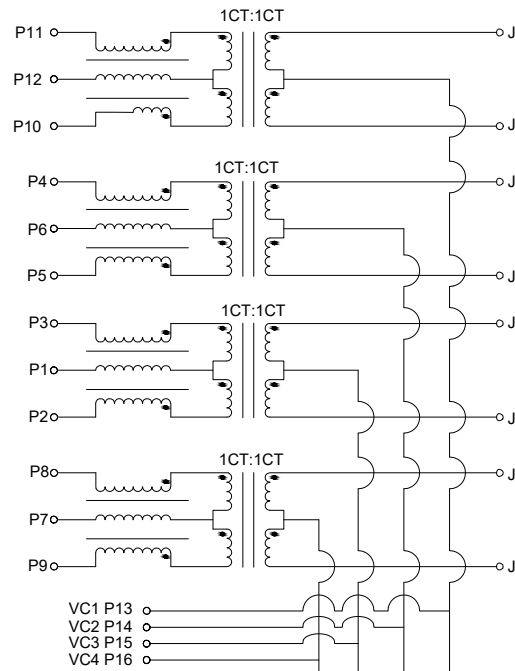
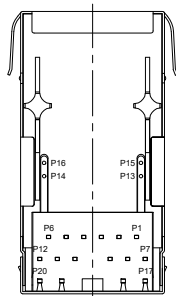

PARAMETER	SPECIFICATIONS	
TURN RATIO @100KHz	(P11~P10):(J1~J2) = 1:1±5% (P4~P5):(J3~J6) = 1:1±5% (P3~P2):(J4~J5) = 1:1±5% (P8~P9):(J7~J8) = 1:1±5%	
PRIMARY INDUCTANCE	350uH Min. @100KHz, 0.1V 8mA DC BIAS	
DC RESISTANCE	1.2OHMS Max.	
INSERTION LOSS	1-100MHz	-1.0dB Max.
	100-125MHz	-1.2dB Max.
RETURN LOSS	1-40MHz	-16dB Max.
	40-60MHz	-12dB Max.
	60-80MHz	-10dB Max.
CROSS TALK	80-100MHz	-8dB Max.
	1-100MHz	-30dB Min.
COMMON MODE REJECTION RATIO	1-100MHz	-30dB Min.
ISOLATION PHY SIDE TO LINE SIDE	2250V DC	
DC CURRENT / VOLTAGE RATING - PSE PINS	350mA Max. @48VDC	

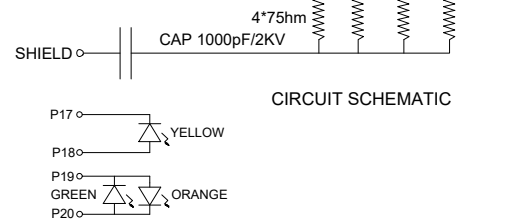
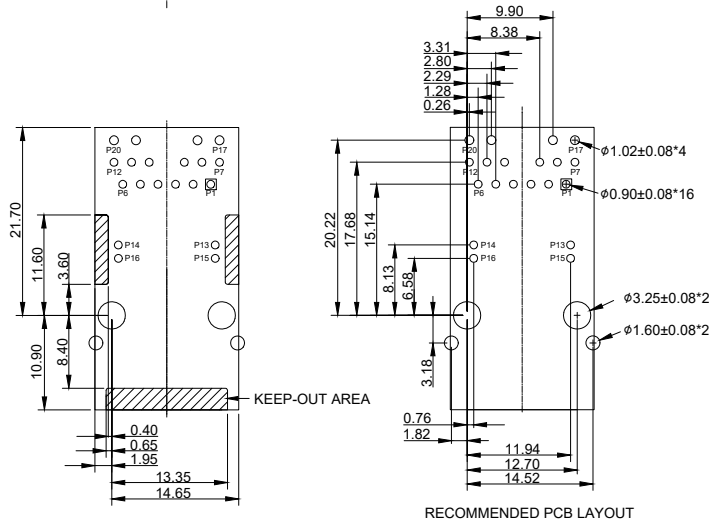

CIRCUIT SCHEMATIC

 E.S. GLOBAL TOP		UNIT	mm
		REVISION	A
PRODUCT		RJ45 1X1 ICM 1000 BASE-T	
DWG NO.		PART NO.	
EZ110S-112PU21-01			
PROJECTION	SCALE	SHEET	1 OF 1
		TOLERANCES ±0.10 UNLESS OTHERWISE SPECIFIED	