



|   |   |                |       |
|---|---|----------------|-------|
| <br><b>E.S. GLOBAL TOP</b> |   | UNIT           | mm    |
|   |   | REVISION       | A     |
| PRODUCT   |   | SFP28 1X1 CAGE |       |
| DWG NO.   | EZS10-1PN1-01   | PART NO.       |       |
| PROJECTION  |  | SCALE          | SHEET |
|   |   | 1 OF 2         |       |

TOLERANCES

X ± 0.25

XX ± 0.13

XXX ± 0.10

ANGLES ± 2°

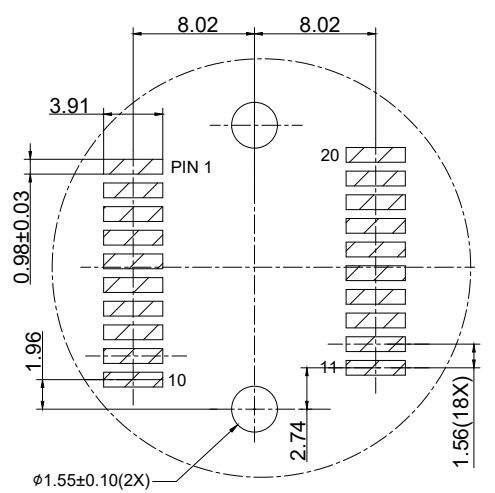
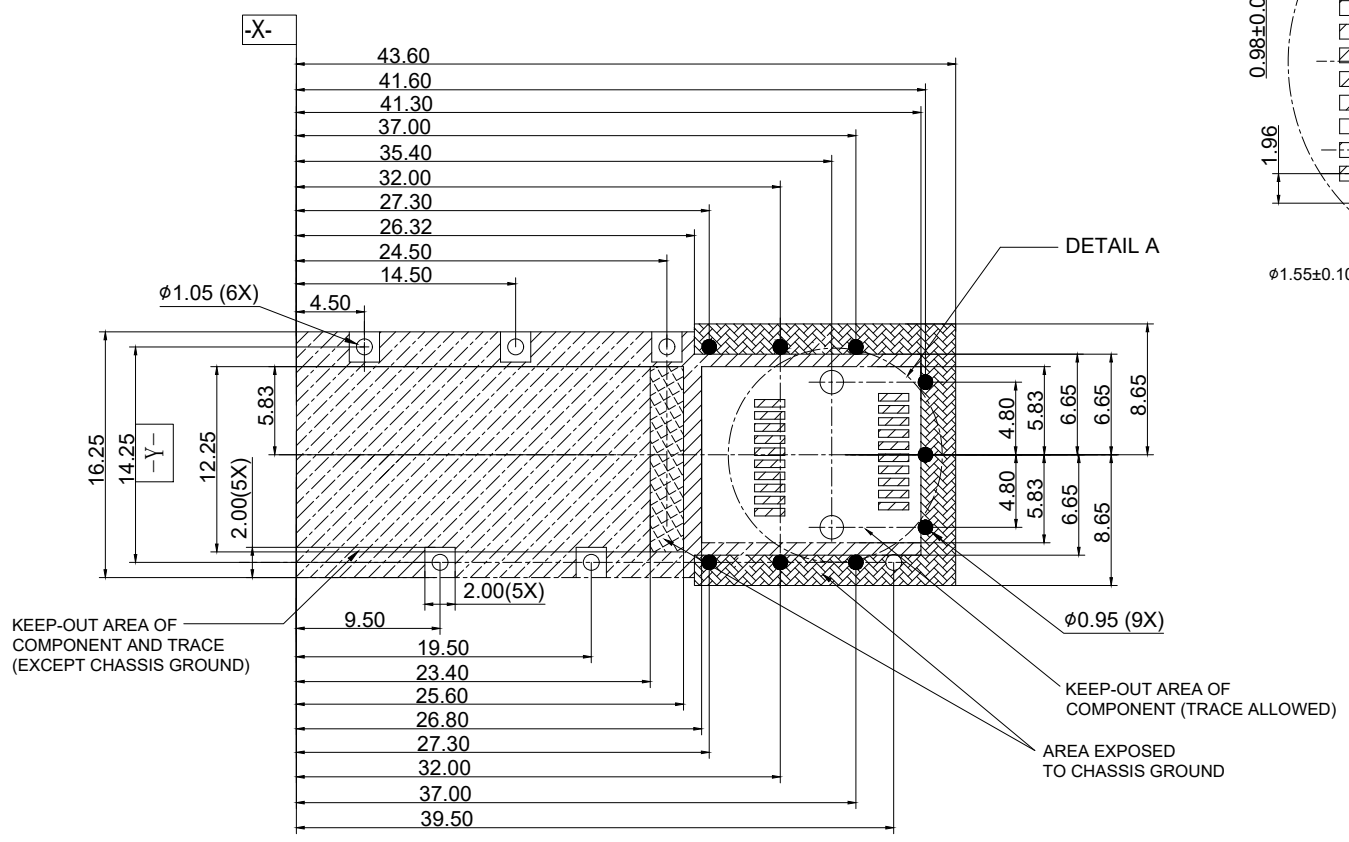

|                            |               |                |        |
|----------------------------|---------------|----------------|--------|
| <br><b>E.S. GLOBAL TOP</b> |               | UNIT           | mm     |
|                            |               | REVISION       | A      |
| PRODUCT                    |               | SFP28 1X1 CAGE |        |
| DWG NO.                    | EZS10-1PN1-01 | PART NO.       |        |
| PROJECTION                 |               | SCALE          | SHEET  |
|                            |               |                | 2 OF 2 |
|                            |               | TOLERANCES     |        |
|                            |               | X ± 0.25       |        |
|                            |               | XX ± 0.13      |        |
|                            |               | XXX ± 0.10     |        |
|                            |               | ANGLES ± 2°    |        |