

NOTE  
 MATERIAL:  
 CONNECTOR CONTACT : PHOSPHOR BRONZE  
 CONNECTOR HOUSING : LCP UL 94V-0 BLACK  
 MOULDED INSERT : THERMOPLASTIC UL 94V-0 BLACK  
 CAGE : COPPER ALLOY  
 LIGHT PIPES : POLYCARBONATE UL 94V-0 TRANSPARENT  
 LIGHT PIPE HOUSING : PBT UL 94V-0 BLACK  
 EMI SPRING : COPPER ALLOY  
 CONTACT MATING AREA : GOLD PLATING 0.76 MICROMETERS MIN. NICKEL  
 CONTACT PRESS-FIT PINS : MATTE TIN PLATING 1.27 MICROMETERS MIN. OVER 1.27 MICROMETERS MIN. NICKEL

DETAIL A

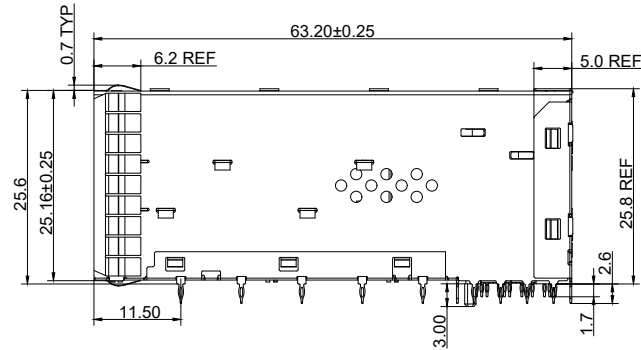

		UNIT	mm
		REVISION	C
PRODUCT		SFP28 2X4 CAGE	
DWG NO.		PART NO.	
EZS10-24N21-01			
PROJECTION	SCALE	SHEET	1 OF 2
		TOLERANCES X ± 0.25 XX ± 0.13 XXX ± 0.10 ANGLES ± 2°	

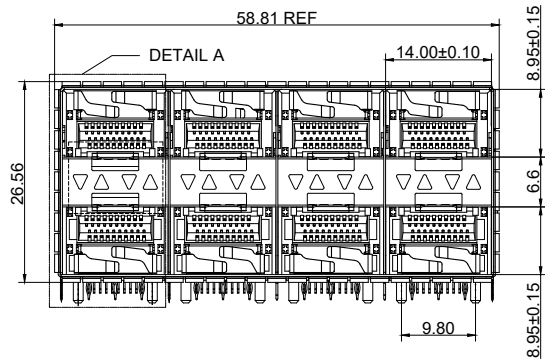
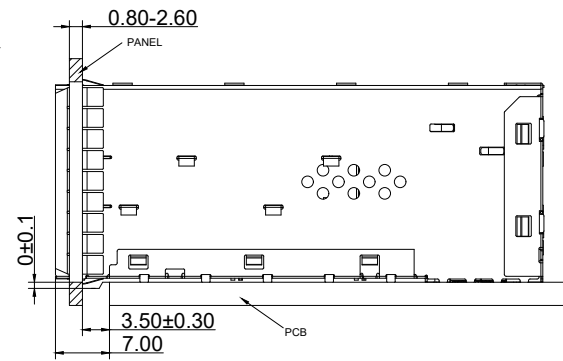
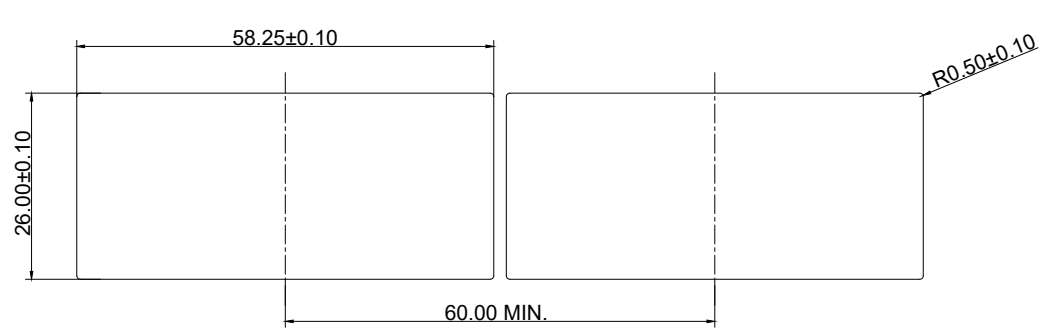

RECOMMENDED PANEL OPENING

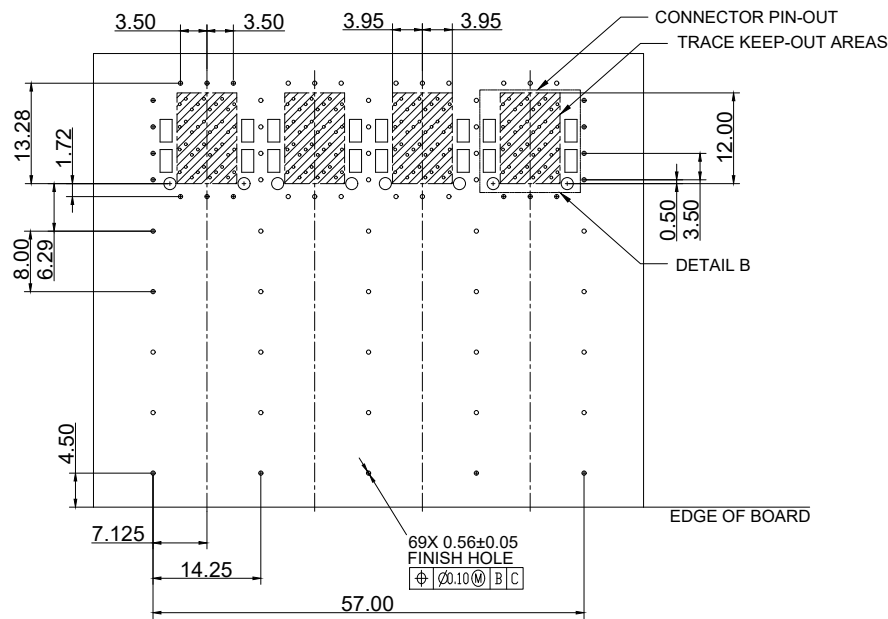

RECOMMENDED PCB LAYOUT

PIN MAP

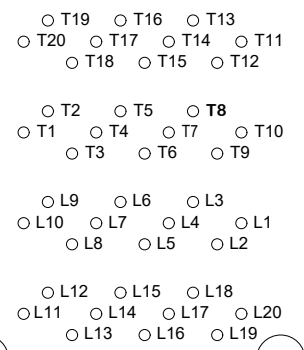

CONNECTOR PIN-OUT

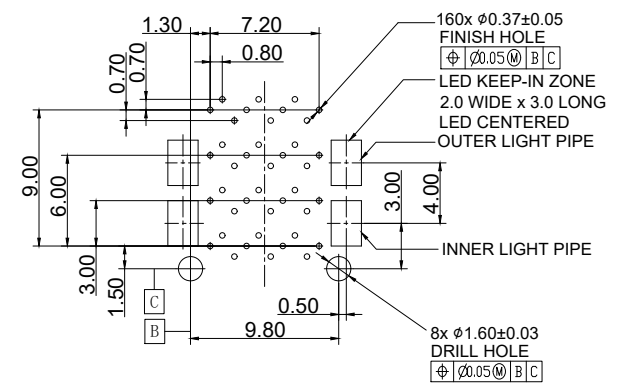

DETAIL B

		UNIT	mm
		REVISION	C
PRODUCT		SFP28 2X4 CAGE	
DWG NO.		PART NO.	
EZS10-24N21-01			
PROJECTION	SCALE	SHEET	2 OF 2
		TOLERANCES	
		X ± 0.25	
		XX ± 0.13	
		XXX ± 0.10	
		ANGLES ± 2°	