

RECOMMENDED PCB LAYOUT

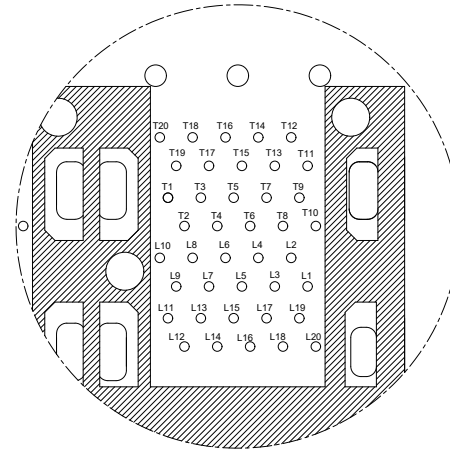

CONNECTOR PIN-OUT

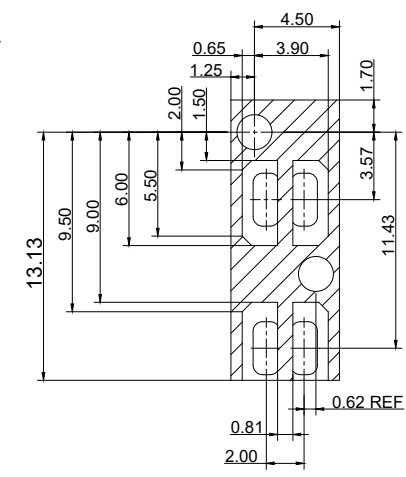

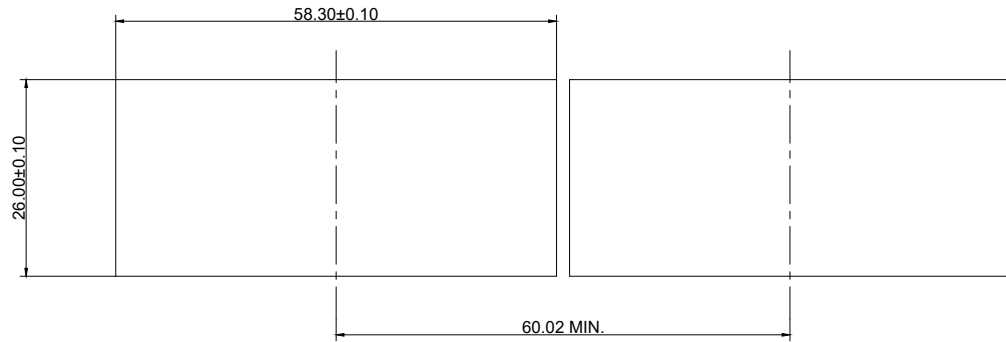

KEEP-OUT ZONE

			UNIT	mm
			REVISION	F
PRODUCT			SFP+ 2x4 CAGE	
DWG NO.		PART NO.		TOLERANCES X ± 0.25 XX ± 0.13 XXX ± 0.10 ANGLES ± 2°
EZSP-24N21-01				
PROJECTION	SCALE	SHEET		
		2 OF 3		

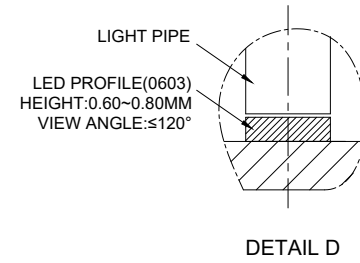
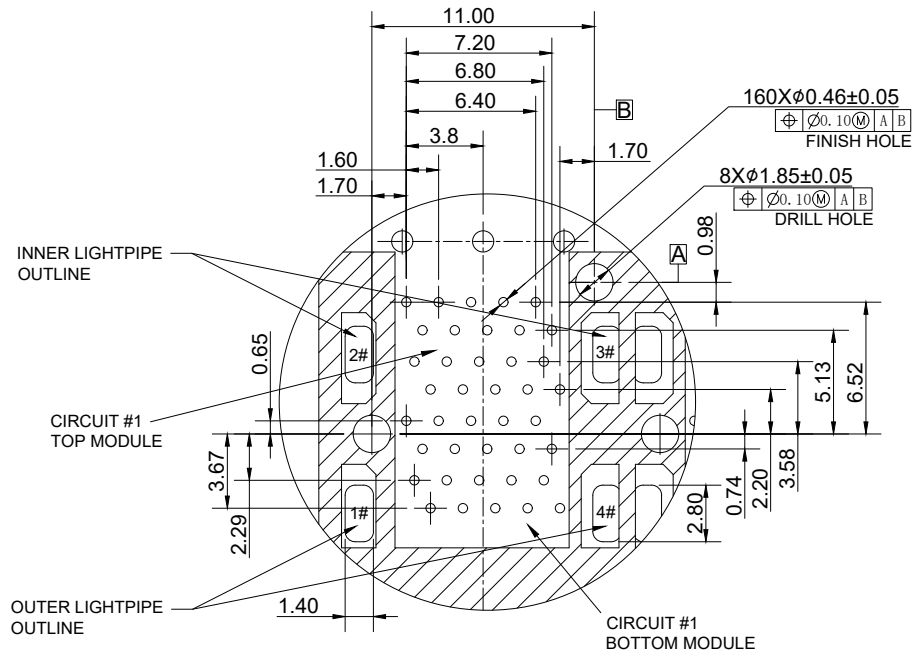
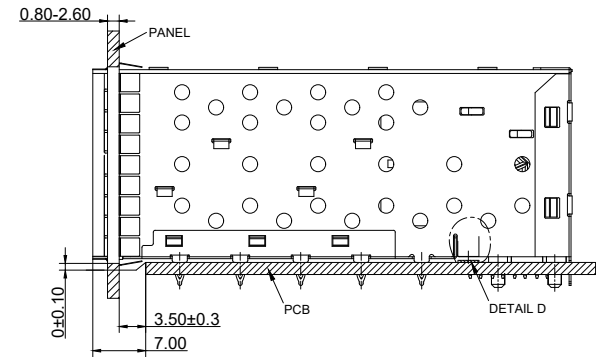

RECOMMENDED PANEL OPENING



 E.S. GLOBAL TOP		UNIT	mm
		REVISION	F
PRODUCT		SFP+ 2x4 CAGE	
DWG NO.		PART NO.	
EZSP-24N21-01			
PROJECTION	SCALE	SHEET	3 OF 3
			
		TOLERANCES	
		X ± 0.25 XX ± 0.13 XXX ± 0.10 ANGLES ± 2°	