

10G SFP+ SR Transceiver

ESTRSCS005

Product Features

- Support rate 1G~10.3125Gbps
- Up to 300m transmission distance on OM3
- Up to 100m transmission distance on OM2 MMF
- 850nm VCSEL and PIN receiver
- SFI electrical interface
- SFP+ MSA package with duplex LC connector
- 2-wire interface for integrated digital diagnostic monitoring
- +3.3V power supply
- Power consumption less than 1W

Absolute Maximum Ratings

Parameter	Symbol	Min.	Max.	Unit
Storage temperature	T _s	-40	+85	°C
Supply voltage	V _{CC3}	0	3.6	V
Relative humidity	RH	5	85	%
RX input average power	P _{max}		0	dBm

Recommended Operating Conditions

Parameter	Symbol	Min.	Typ.	Max.	Unit	Note
Operating case temperature	T _c	0		+70	°C	C
Operating case temperature	T _c	-40		+85	°C	I
Power supply voltage	V _{CC3}	3.135	3.3	3.465	V	
	I _{CC3}			300	mA	
Power dissipation	P _D			1	W	
Data rate		1	10.3125		Gbps	
Transmission distance	OM3			300	m	

Transmitter Characteristics

Parameter	Symbol	Min.	Typ.	Max.	Unit	Note
Center wavelength	λ_c	840	850	860	nm	*
Laser off power	Poff			-30	dBm	
Average optical power	Pavg	-8.2		-1	dBm	For 10.3G
Optical modulation amplitude	OMA	-4.3			dBm	For 10.3G
RMS spectral width				0.45	nm	
Extinction ratio	ER	3			dB	For 10.3G
Transmitter dispersion penalty	TDP			3.9	dB	
Relative intensity noise	Rin			-128	dB/Hz	
Operating data rate			10.3125		Gbps	
Optical eye mask margin		5			%	
Tx input diff swing	VI	180		1200	mV	
Tx_disable, disable		2		VCC	V	
Tx_disable, enable		VEE		VEE+0.8	V	

Note: average optical power shall be measured using the methods specified in TIA/EIA-455-95

Receiver Characteristics

Parameter	Symbol	Min.	Typ.	Max.	Unit	Note
Center wavelength	λ_r	840	850	860	nm	
Receiver sensitivity (OMA)			-14	-11.1	dBm	For 10.3G
LOS assert	LOS A	-30			dBm	
LOS dessert	LOS D			-14	dBm	For 10.3G
LOS hysteresis	LOSH	0.5			dB	
Overload	Pin	0			dBm	
Return loss of receiver		12			dB	
Operating data rate			10.3125		Gbps	
Rx output diff swing	Vo	370		850	mV	
Rx output rise and fall time	Tf/Tf		50		ps	20% ~ 80%

Note: receiver sensitivity is informative and shall be measured with conformance test signal for BER=1x10⁻¹²

Control and Status I/O Timing Characteristics

Parameter	Symbol	Min.	Typ.	Max.	Unit	Note
TX disable assert time	t_off			100	μs	1
TX disable negate time	t_on			2	ms	2
Time to initialize including reset of TX_fault	t_init			300	ms	3
TX fault assert time	t_fault			1	ms	4
Tx_fault reset	t_reset	10			μs	5
LOS assert time	t_loss_on			100	μs	6
LOS deassert time	t_loss_off			100	μs	7
Serial ID clock rate	f_serial_clock	100		400	kHz	

Note:

1. Time from rising edge of TX disable to when the optical output falls below 10% nominal
2. Time from falling edge of TX disable to when the modulated optical output rises above 90% of nominal
3. From power on or negation of TX fault using TX disable
4. Time from fault to TX fault on
5. Time TX disable must be held high to reset TX_fault
6. Time from LOS state to RX LOS assert
7. Time from non-LOS state to RX LOS deassert

Pin Descriptions

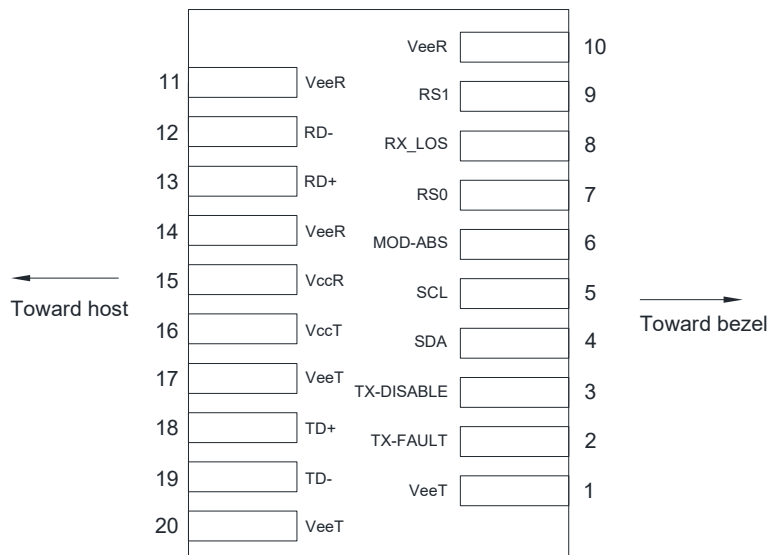

Pin	Symbol	Descriptions	Note
1	VeeT	Module transmitter ground	1
2	TX_fault	Module transmitter fault	2
3	TX_disable	Transmitter disable; turns off transmitter laser output	3
4	SDA	2-wire serial interface data line (same as MOD-DEF2 as defined in INF-8074i)	4
5	SCL	2-wire serial interface clock (same as MOD-DEF1 as defined in INF-8074i)	4
6	MOD_ABS	Module absent, connected to VeeT or VeeR in the module	5
7	RS0	Rate select 0, optionally controls SFP+ module receiver, when high input data rate 10.3GBd and when low input data rate 1.25GBd	6
8	RX_LOS	Receiver loss of signal indication (in FC designated as RX_LOS, in SONET designated as LOS, and in Ethernet designated as signal detect)	2
9	RS1	Rate select 1, optionally controls SFP+ module transmitter, when high input data rate 10.3GBd and when low input data rate 1.25GBd	6
10	VeeR	Module receiver ground	1
11	VeeR	Module receiver ground	1
12	RD-	Receiver inverted data output	
13	RD+	Receiver non-inverted data output	
14	VeeR	Module receiver ground	1
15	VccR	Module receiver 3.3V supply	
16	VccT	Module transmitter 3.3V supply	
17	VeeT	Module transmitter ground	1
18	TD+	Transmitter non-inverted data input	
19	TD-	Transmitter inverted data input	
20	VeeT	Module transmitter ground	1

Note:

1. The module signal ground pins, VeeR and VeeT, shall be isolated from the module case
2. This pin is an open collect/drain output pin and shall be pulled up with 4.7k-10kohms to Host_Vcc on the host board. Pull ups can be connected to multiple power supplies. However the host board design shall ensure that no module pin has voltage exceeding module VccT/R + 0.5V
3. This pin is an open collect/drain input pin and shall be pulled up with 4.7k-10kohms to VccT in the module
4. See SFF-8472 4.2 2-wire electrical specification
5. This pin shall be pulled up with 4.7k-10kohms to Host_Vcc on the host board
6. If implementing, SFF-8079 pin 7 and 9 are used for AS0 and AS1 respectively

Block diagram of transceiver

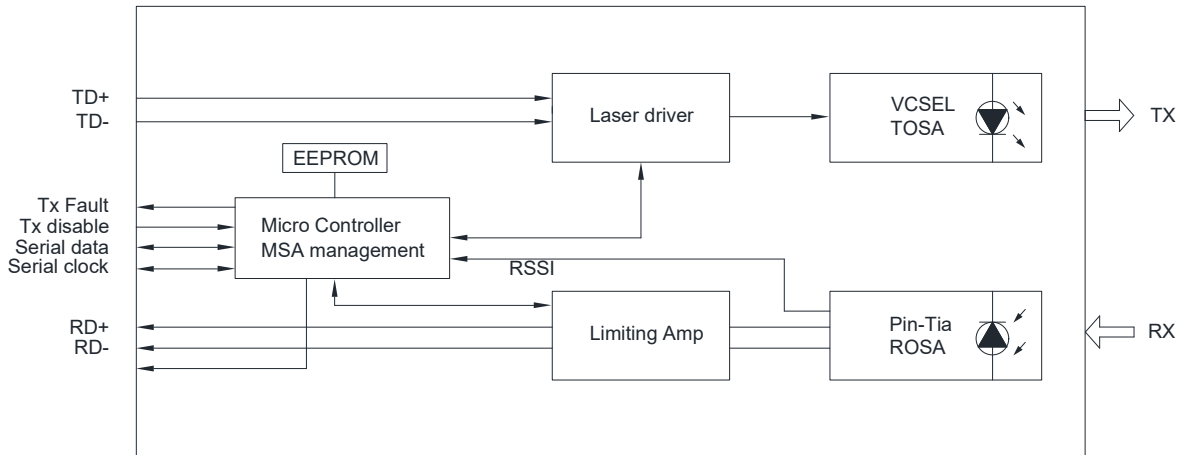

Recommended interface circuit

