

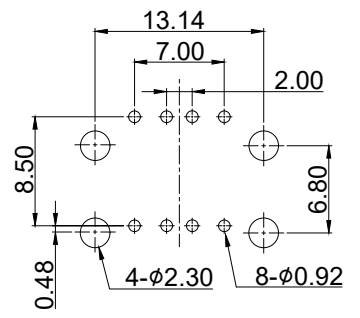

NOTES:
MECHANICAL
 HOUSING : PBT BLACK UL 94V-0
 CONTACT : C2680 GOLD PLATING
 BACK PLATE : PBT BLACK UL 94V-0
 SHELL : C2680 NICKEL PLATED

ELECTRICAL
 VOLTAGE RATING : 30 VAC
 CURRENT RATING : 1AMP
 CONTACT RESISTANCE : 30mΩ MAX.
 INSULATION RESISTANCE : 1000 MΩ MIN.
 DIELECTRIC STRENGTH : 500V AC

ENVIRONMENTAL
 TEMPERATURE RANGE : -20°C ~ +60°C

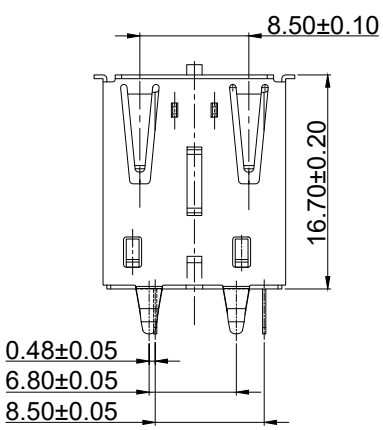
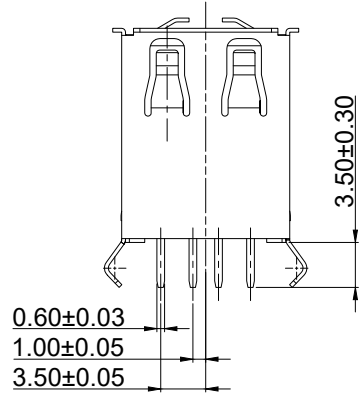
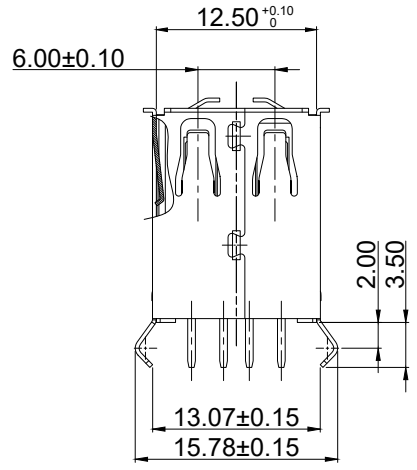
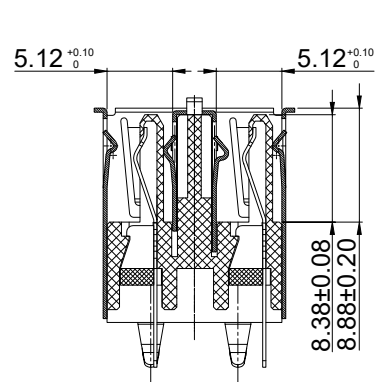

RECOMMENDED PCB LAYOUT

 E.S. GLOBAL TOP		UNIT	mm
		REVISION	A-0
PRODUCT		USB 2.0 TYPE A DUAL PORTS	
DWG NO.		PART NO.	
EZU20A-2DV1-01			
PROJECTION	SCALE	SHEET	
		1 OF 1	

TOLERANCES
 X.±0.38 X.°4.0
 .X±0.25 .X°2.0
 .XX±0.20
 .XXX±0.10